



ligne SAUZE



Ekilux est une société d'édition, située en Provence, dans le sud de la France. Créée par Sebastien Sauze, le fils de Max Sauze, qui reprend la production des luminaires en lames d'aluminium conçus à la fin des années 60 depuis 2008.

Ces luminaires s'inscrivent désormais dans un mouvement design et contemporain. Telle une renaissance, ils assurent la transition entre la période novatrice et sans limite des 70, et le marché actuel.

La marque " Ligne SAUZE" évolue et s'enrichit de nouveautés depuis maintenant plus d'une décennie, cumulant ainsi plus de 50 années de création et de savoir-faire. La ligne esthétique reste la même tout en apportant certains changements propres à la demande contemporaine.

Ligne SAUZE, c'est d'abord un équilibre, une harmonie entre les formes. L'ajustement des proportions, les matières qui jouent sur l'aspect de surface, et au final le rendu lumineux qu'il faut apprivoiser. Chacun de ces 4 éléments a ses propres valeurs, caractéristiques et limites, puis interagit avec les autres.

Max Sauze est passé maître dans l'art de jouer avec ces éléments. Depuis plus de 60 ans il imagine, conçoit, crée toutes sortes de formes en multipliant les matériaux. Ces formes peuvent être libres de toutes références, de toutes connotations, pour être simplement ce qu'elles sont, c'est-à-dire belles et mystérieuses à regarder, en laissant l'observateur ouvert sur son imaginaire, ou bien liées à un sujet, phrase, expression, réflexion, jeu de mots, pour être sublimées ou, d'une manière plus ludique, tournées en dérision avec une touche de poésie. Telles des sculptures, les luminaires Ligne SAUZE se doivent d'être aussi beaux éteints qu'éclairés.

Pour conserver cet état d'esprit, Sebastien Sauze a voulu concentrer son travail entre art et artisanat. Les valeurs s'appuient sur une relation avec la matière. A l'image d'un ébéniste qui caresse le bois, le métal se doit d'être maîtrisé, il cache une invisible alchimie.

Le savoir-faire est au centre de l'activité et détermine l'objet fini. Toutes les opérations sont réalisées à la main. De la matière première à la transformation en objet fini, les opérations se comptent par milliers pour les grands modèles.

Chaque étape d'un luminaire nécessite beaucoup de temps, d'espace et une dose de passion.

L'outil mécanique est un compagnon, souvent conçu pour un besoin spécifique, il forme un couple homme machine en perpétuel quête d'amélioration. Les formes sont variées, évoluant dans une géométrie spatiale où l'évidence prend toute sa force.

Prenant exemple sur ce que la nature a façonné, par la logique du chemin le plus efficace, Ligne SAUZE s'efforce d'en reproduire les méthodes. D'un désordre relatif renaît une organisation, par la répétition, le tri, l'alignement. Une certaine beauté apparaît, telle que nous la percevons dans notre culture.

Pour répondre aux besoins les plus variés de la demande, la gamme des luminaires s'étend de la petite lampe de chevet au lustre de 1 mètre de diamètre, en passant par des lampes à poser sur table ou sur sol.

L'offre globale permet de se placer au sein des intérieurs les plus variés, qu'ils soient contemporains ou anciens. C'est par cette identité sculpturale que les lumières Ligne SAUZE marquent leurs empreintes.

Based in Provence in the South of France, Ekilux was born of Sebastien Sauze's desire to relaunch production of the iconic slatted aluminium lamps designed by his father Max Sauze at the end of the 1960s. Since their inception, these lamps have never lost their relevance to contemporary design. Like a small Renaissance, they bridge the gap between the innovative 70s, when designers were bursting with creativity, and today's globalised economic market.

The brand "MAX SAUZE" evolving and enriched with new a few years now. Cosmetic line remains the same while making some changes specific to contemporary application.

To mark this evolution and ensure its sustainability Sébastien created "Ligne SAUZE" brand which now includes the whole current range and future creations.

"Ligne SAUZE" meaning balance and light - expresses the quest for harmonious equilibrium between form, proportion, materials and surface effects, which work together to yield a particular quality of light. Each of these four elements has its own values, characteristics and limits, alone and in interaction with the others.

Max Sauze has achieved total mastery over these elements. For over 60 years he has been conceiving, designing and creating all kinds of shapes in a multiplicity of materials. These forms are sometimes devoid of any reference or connotation - they are what they are, simply: objects of mystery and beauty, allowing the viewer's imagination free rein - or they can give playful, sometimes poetic, expression to his associations with a subject, a sentence, an expression, a thought or a pun. Like sculptures, Ligne Sauze's lamps are designed to be always beautiful, whether they are lit or not.

In the same spirit, Sebastien Sauze decided his work would also marry art with craftsmanship. His values arise from his deep feeling for his materials. Like the wood smoothed by the experienced hands of a cabinetmaker, metal also needs to be mastered to reveal its hidden alchemy; it has a past.

The highly skilled production at the heart of Sebastien's workshop is essential to the finished object. Everything is done by hand, from raw material to transformation into a completed object, in a series of deft operations that can run into the thousands on larger models.

Each stage in making a lamp requires a great deal of time, sufficient space - and passion.

Mechanical tools are faithful companions. Often designed for a very specific purpose, each tool continues to evolve in response to the artisan's needs as he constantly seeks to improve his workmanship. The shapes are varied, unfolding in a spatial geometry where the form they take becomes self-evident.

Drawing inspiration from the workings of nature which follow the path of least resistance, Ligne SAUZE endeavours to reproduce its methods. From relative disorder emerges organisation, through a process of repetition, sorting and alignment. A certain form of beauty is born, as viewed through the eyes of our culture.

To meet our customers' varied needs, our range extends from small bedside lamps, through table lamps and floor lamps, to chandeliers with a one-metre diameter.

This wide range means Ligne SAUZE lamps are a perfect fit for any interior, whether contemporary or traditional, and it is through their sculptural identity that they can be recognised anywhere.

CONTACT

TEL: (+33) 04 42 92 88 99

MOB: (+33) 06 13 43 69 34

MAIL: ekilux@gmail.com

WEB: www.lignesauze.fr

FACEBOOK: Ligne SAUZE

INSTAGRAM: lignesauze

SIÈGE: Ekilux SAS, 22 av Badonviller 13410 LAMBESC



SOMMAIRE

ALTAIR 5-12
SUSPENSION 5-8
LAMPE 9-10
APPLIQUE 11-12

ANDROMEDE 13-14

ATLAS 15-20

AURIGA 21-30
SUR PIÈTEMENT 21-24
CUBE 25-26
SUSPENSION 27-30

CASSIOPÉE 31-40
9 PLANS 33-36
7 PLANS 37-38
5 PLANS 39-40

COPERNIC 41-42

GANYMEDE 43-50

GANYMEDE II 51-52

ORION 53-78
ORION 48 55-60
ORION 60 61-66
ORION 75 67-70
ORION 100 71-76
ORION 130 77-78

PROJET TCHOURI 79-80

ALTAÏR SUSPENSION

Dimensions: 17x17x16 cm
Ref: ALT17S`
300 gr équipée / complete

Dimensions: 25x25x25cm
Ref: ALT25S
750 gr équipée / complete

Source: E14 / LED

17 / 25 cm

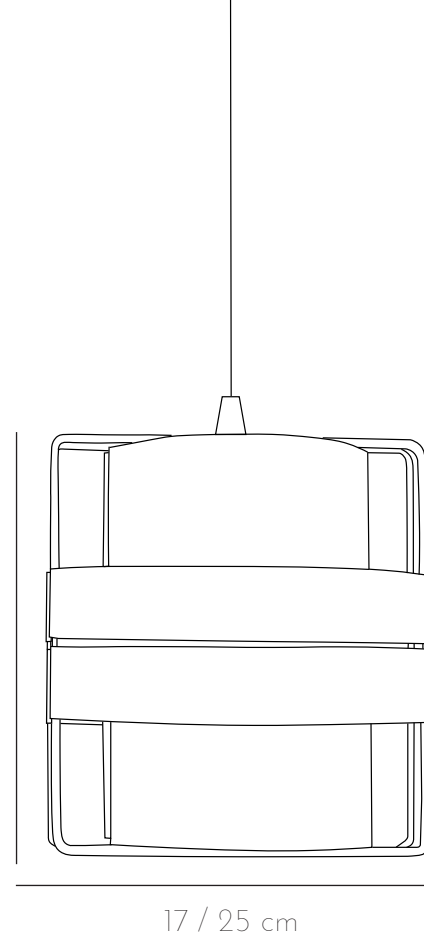



ALTAIR SUSPENSION





ALTAÏR LAMPE

Dimensions: 17x17x21 cm
Ref: ALT17T
300 gr équipée / complete

Dimensions: 25x25x32 cm
Ref: ALT25T
700 gr équipée / complete

Source: E14

17 / 25 cm

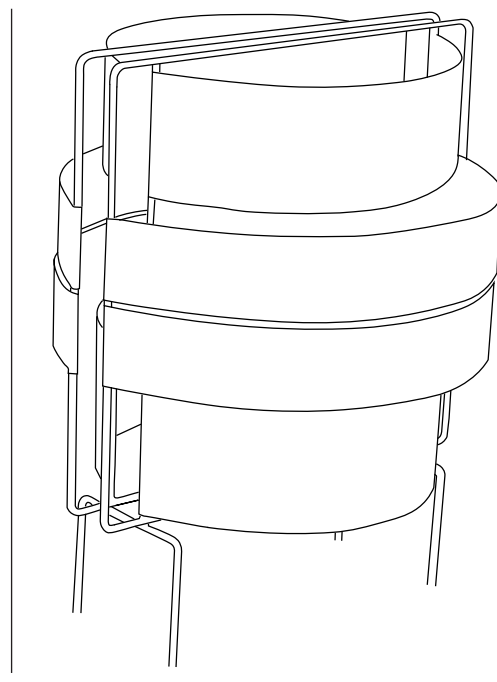

17 / 25 cm





ALTAÏR APPLIQUE

Dimensions: 25x25x14 cm
Ref: ALT25A
700 gr équipée / complete
Source: E14

Dimensions: 17x17x10 cm
Ref: ALT17A
400 gr équipée / complete
Source: G9 / LED

17 / 25 cm

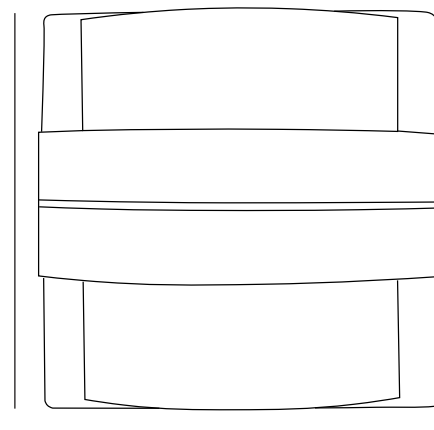

17 / 25 cm





ANDROMÈDE

SUSPENSION

Dimensions: 29X24 cm
Ref: AND545S
1,1 kg équipée / complete

Dimensions: 40x31 cm
Ref: AND560S
1,5 kg équipée / complete

Source: E27-LED / halo

TABLE

Dimensions: 29x32 cm
Ref: AND545T
1,1 kg équipée / complete
Source: E14-LED

29 / 40 cm

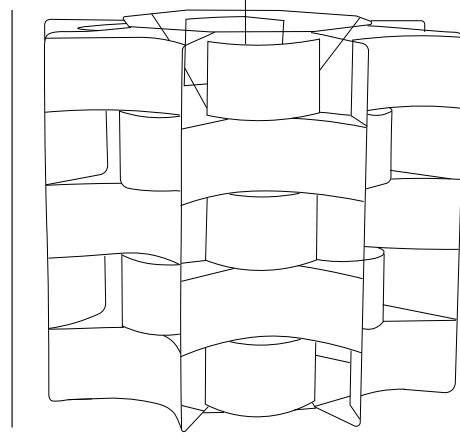

24 / 31 cm





ATLAS

Dimensions: 32x32x14 cm

Ref: AT32

1 kg équipée / complete

Dimensions: 42x42x17 cm

Ref: AT42

1,5 kg équipée / complete

Source: E27-LED

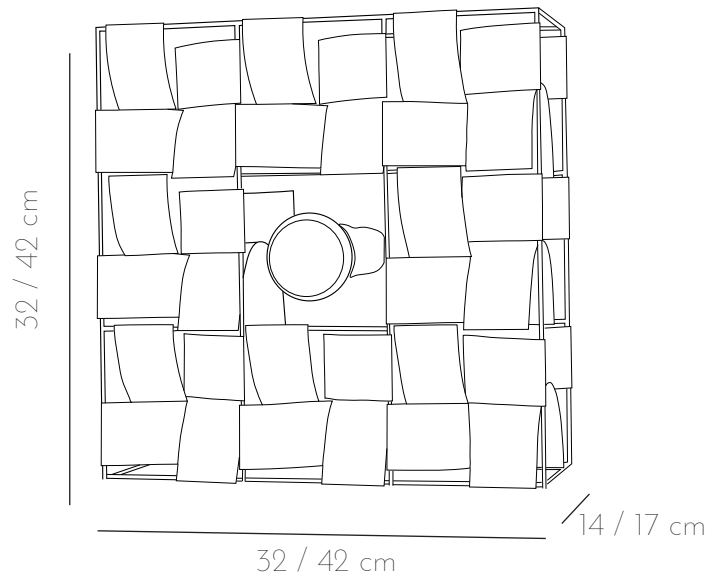



ATLAS





ATLAS



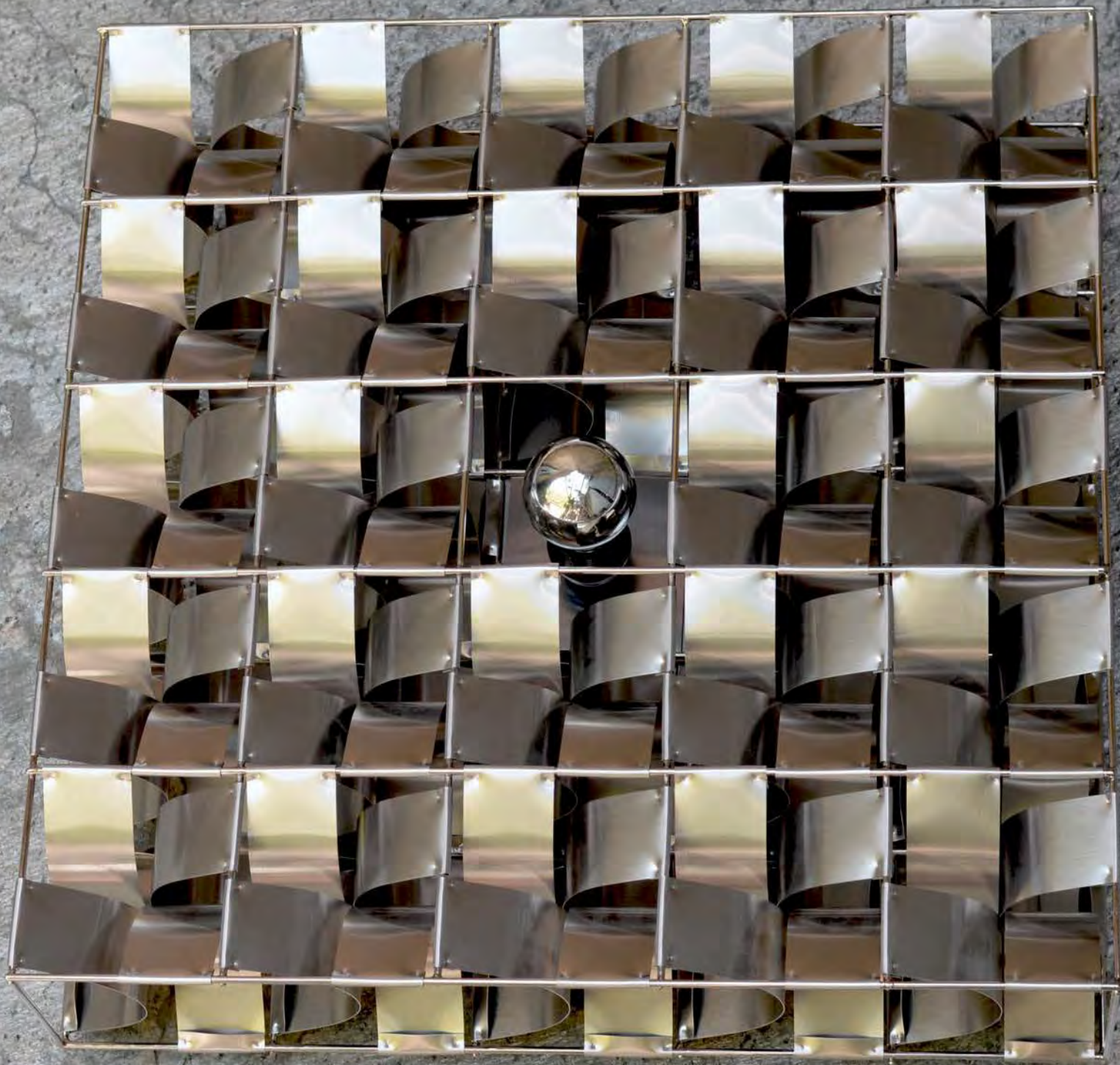

PROJET 55x55cm

AURIGA SUR PIÈTEMENT

Dimensions: 33x70 cm
Ref: AU545T
1,2 kg équipée / complete
Source: E14-LED

Dimensions: 40x105 cm
Ref: AU560P93
4 kg équipée / complete
Source: E27-LED



70 / 105 cm

33 / 40 cm

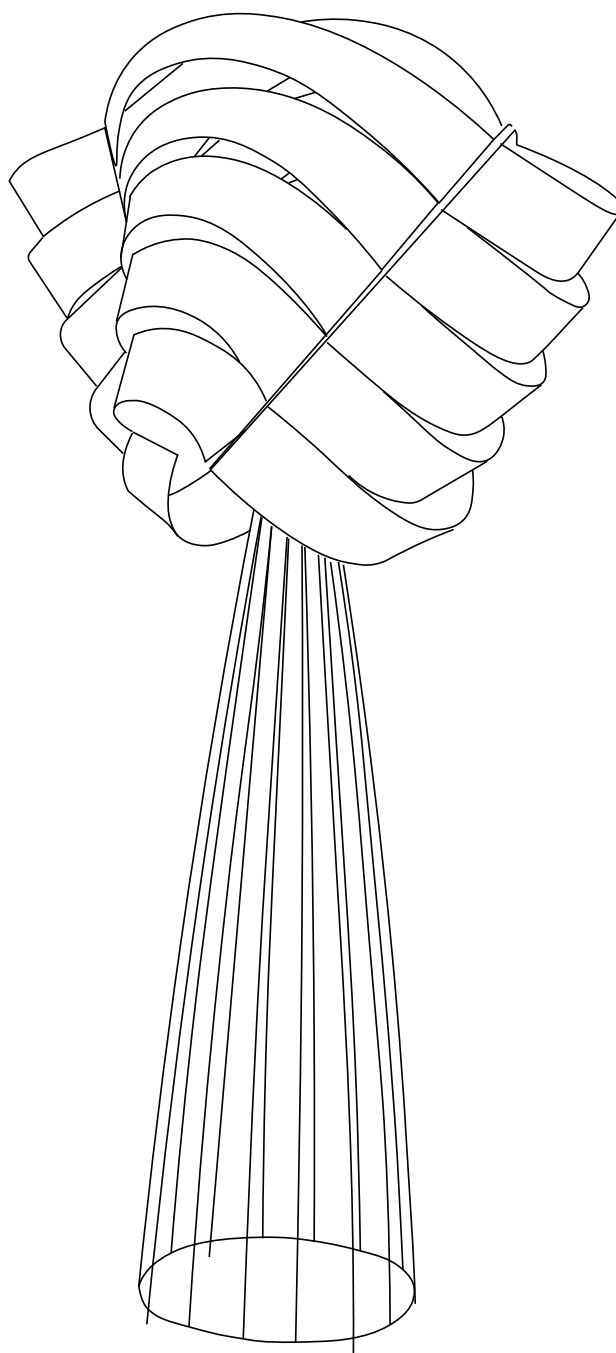



AURIGA SUR PIÈTEMENT





AURIGA CUBE

Dimensions: 29x29cm
Ref: AU545C
1 kg équipée / complete
Source: E14-LED

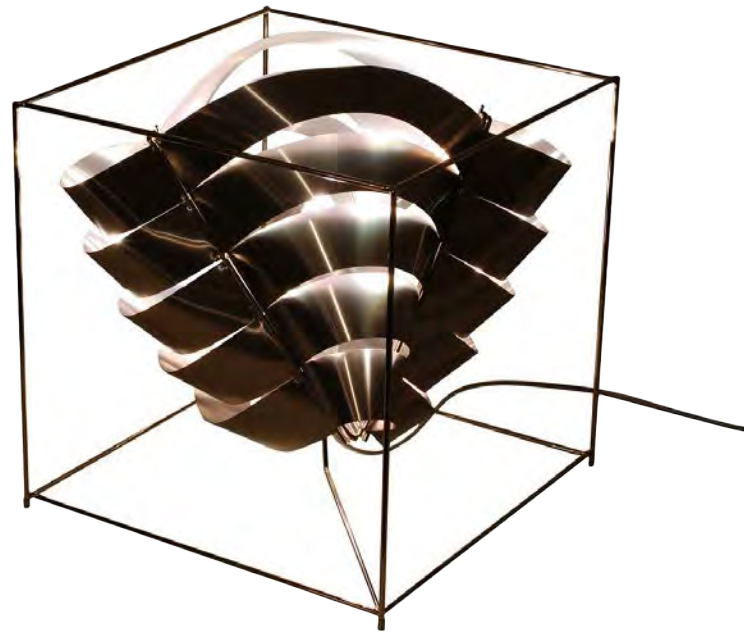
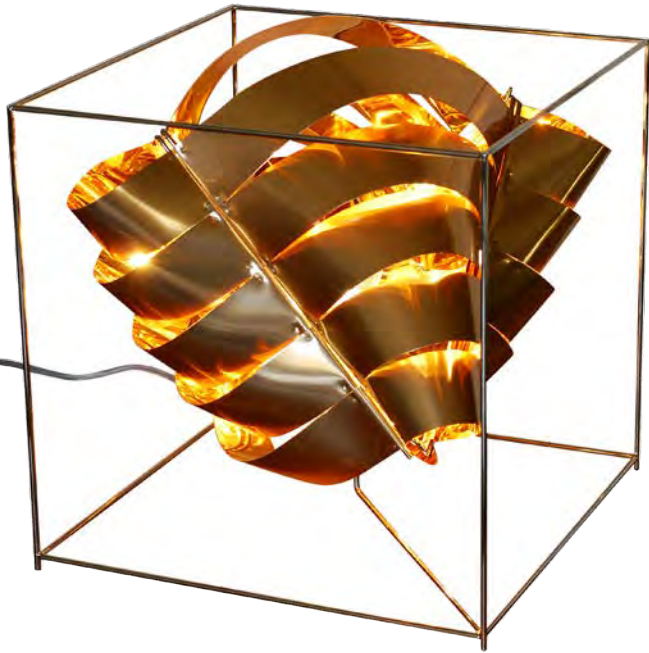
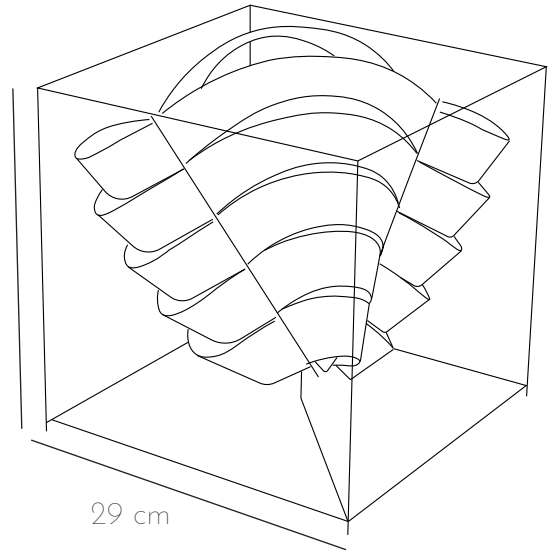



AURIGA SUSPENSION

Dimensions: 35x30cm
Ref: AU545S
900 gr équipée / complete
Source: E14-LED

Dimensions: 40x35cm
Ref: AU560S
1,2 kg équipée / complete
Source: E27-LED

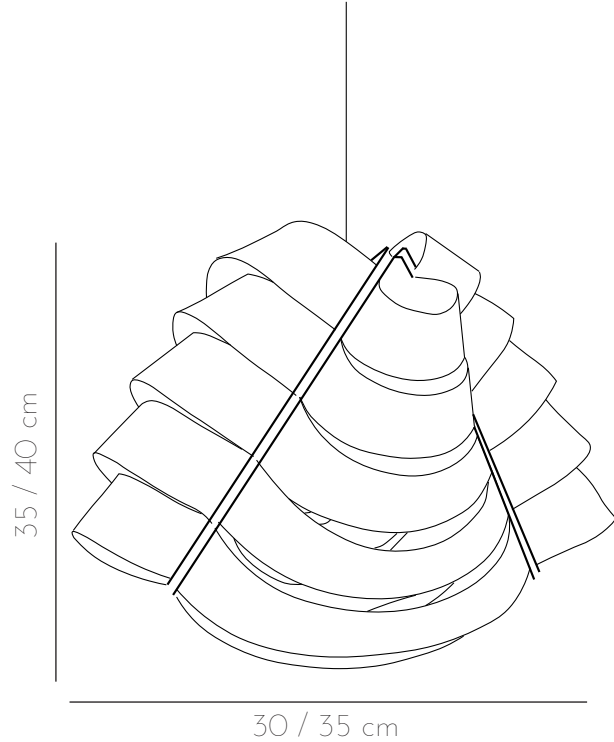



AURIGA SUSPENSION





CASSIOPEE

5 PLANS

Dimensions: 50x50 cm

Ref: CA550

1,6 kg équipée / complete

Source: E27

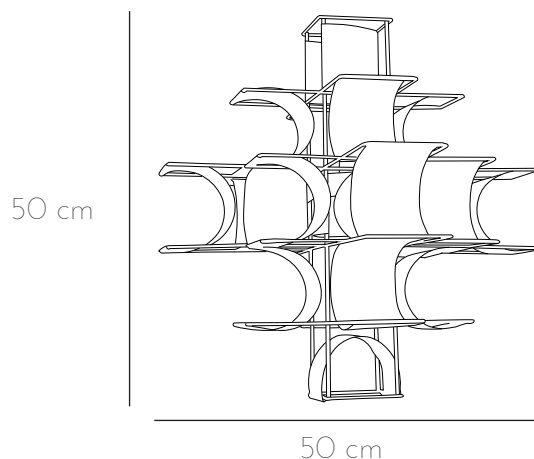

7 PLANS

Dimensions: 75x75 cm

Ref: CA775

5,6 kg équipée / complete

Source: E27

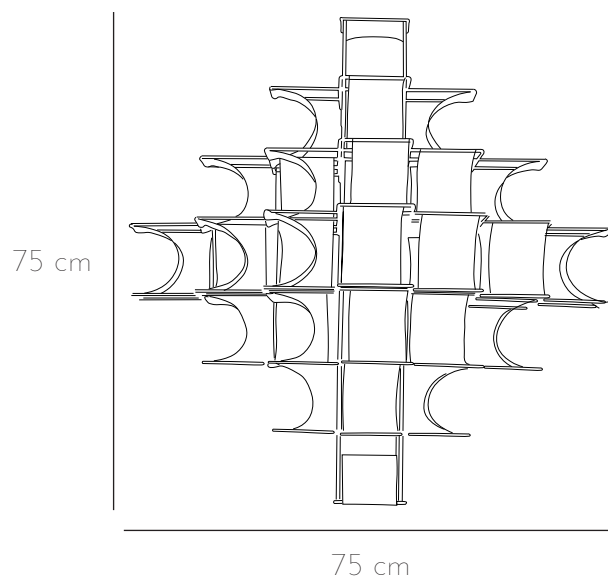

9 PLANS

Dimensions: 75x75 cm

Ref: CA975

7 kg équipée / complete

Source: E27

Dimensions: 100x100 cm

Ref: CA9100

12 kg équipée / complete

Source: x2 E27-LED

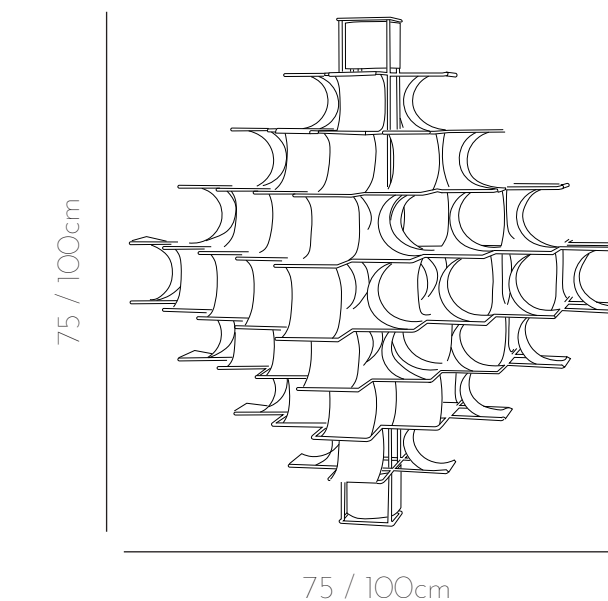



CASSIOPEE 9 PLANS





CASSIOPÉE 9 PLANS



33





CASSIOPEE 7 PLANS

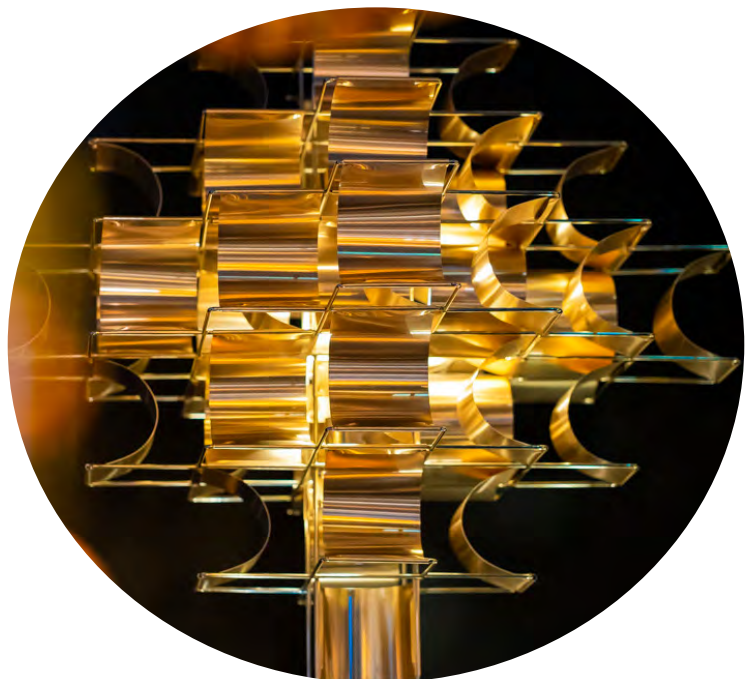



CASSIOPEE 5 PLANS



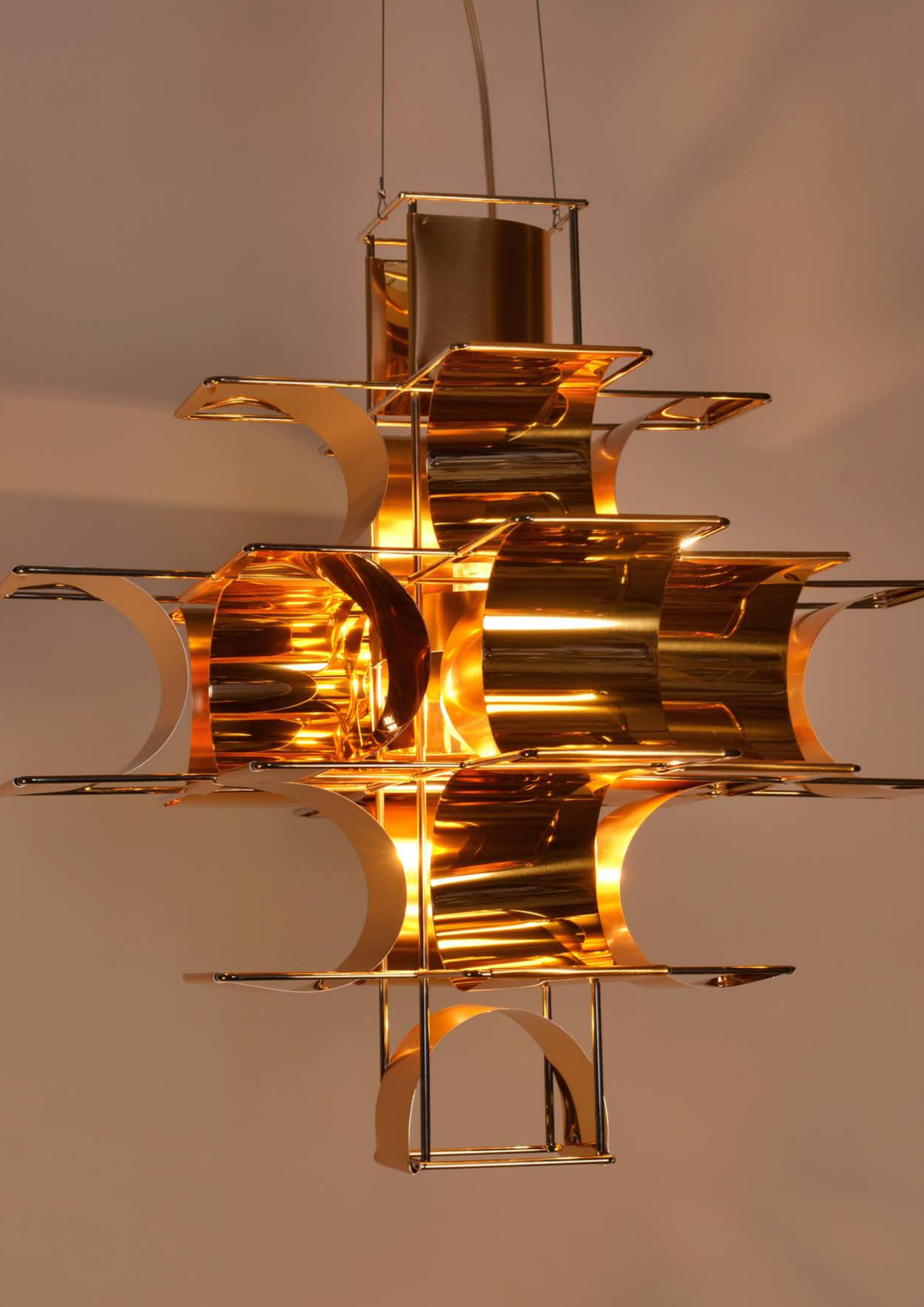

COPERNIC

Dimensions: 110x25 cm
Ref: COP
3 kg équipée / complete
Source: E27-LED

110 cm

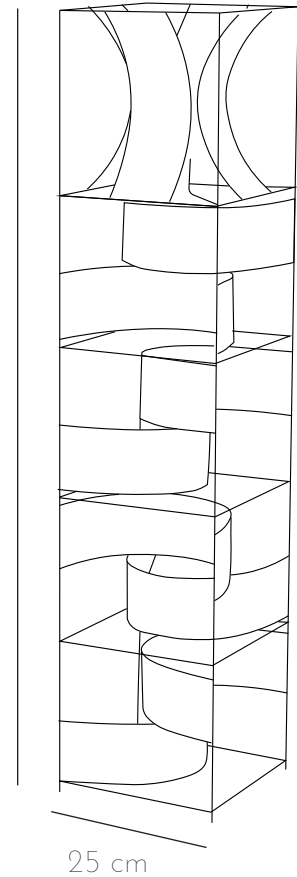



GANYMEDE

Dimensions: 32x14 cm
Ref: GA
550 gr équipée / complete
Source: G9-LED / Halo

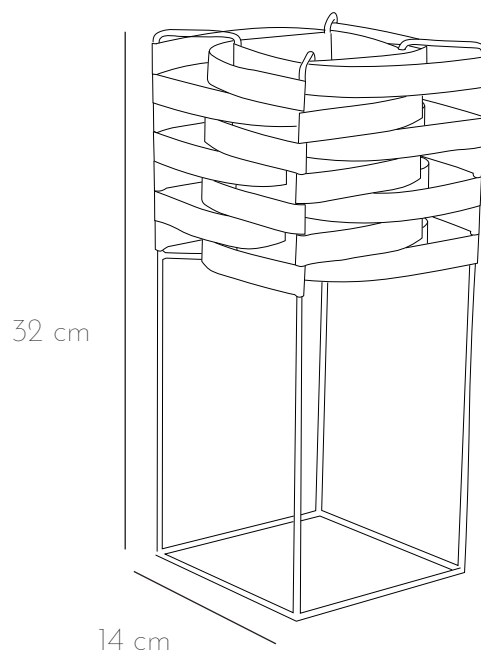



GANYMEDE

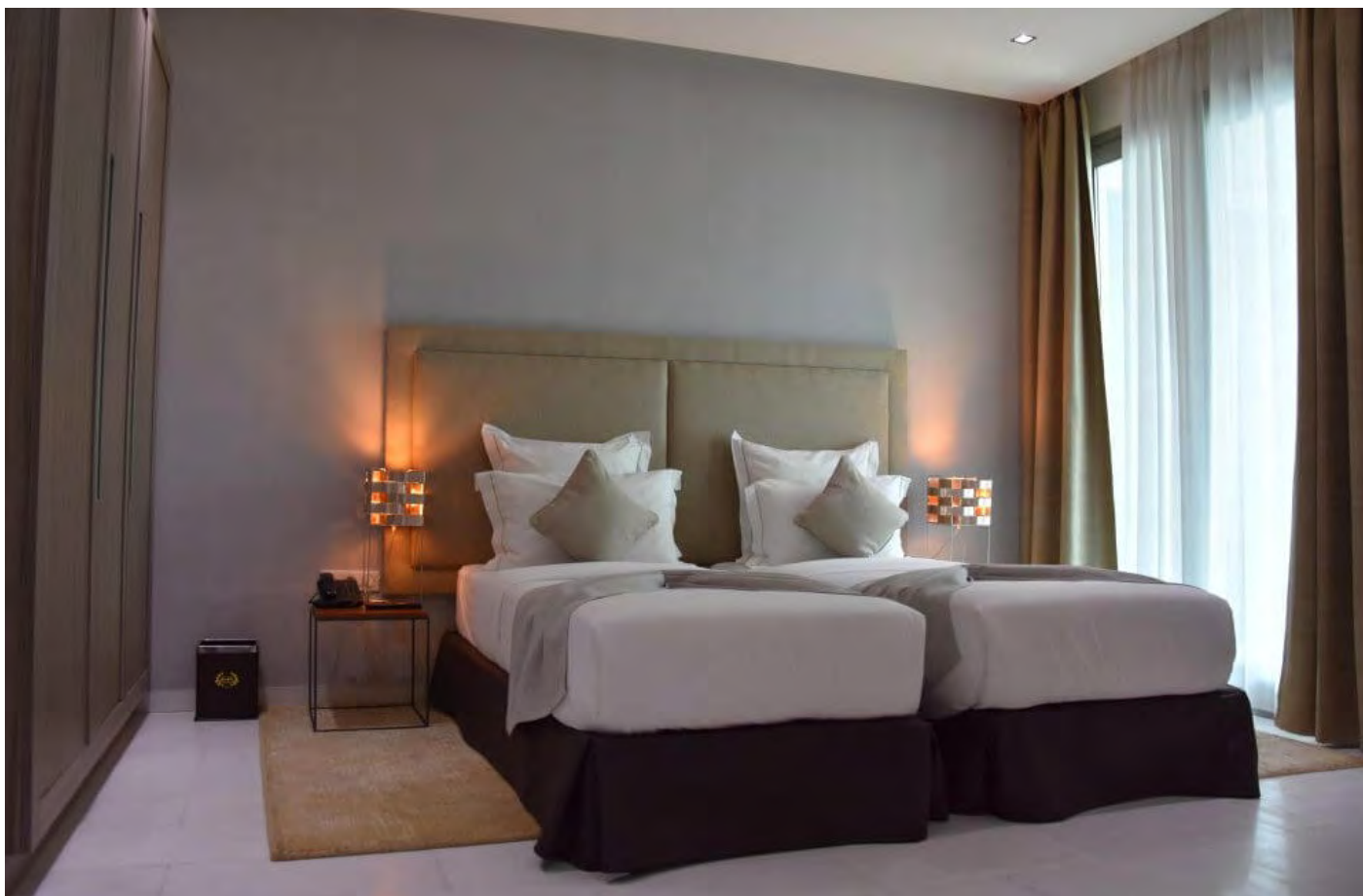

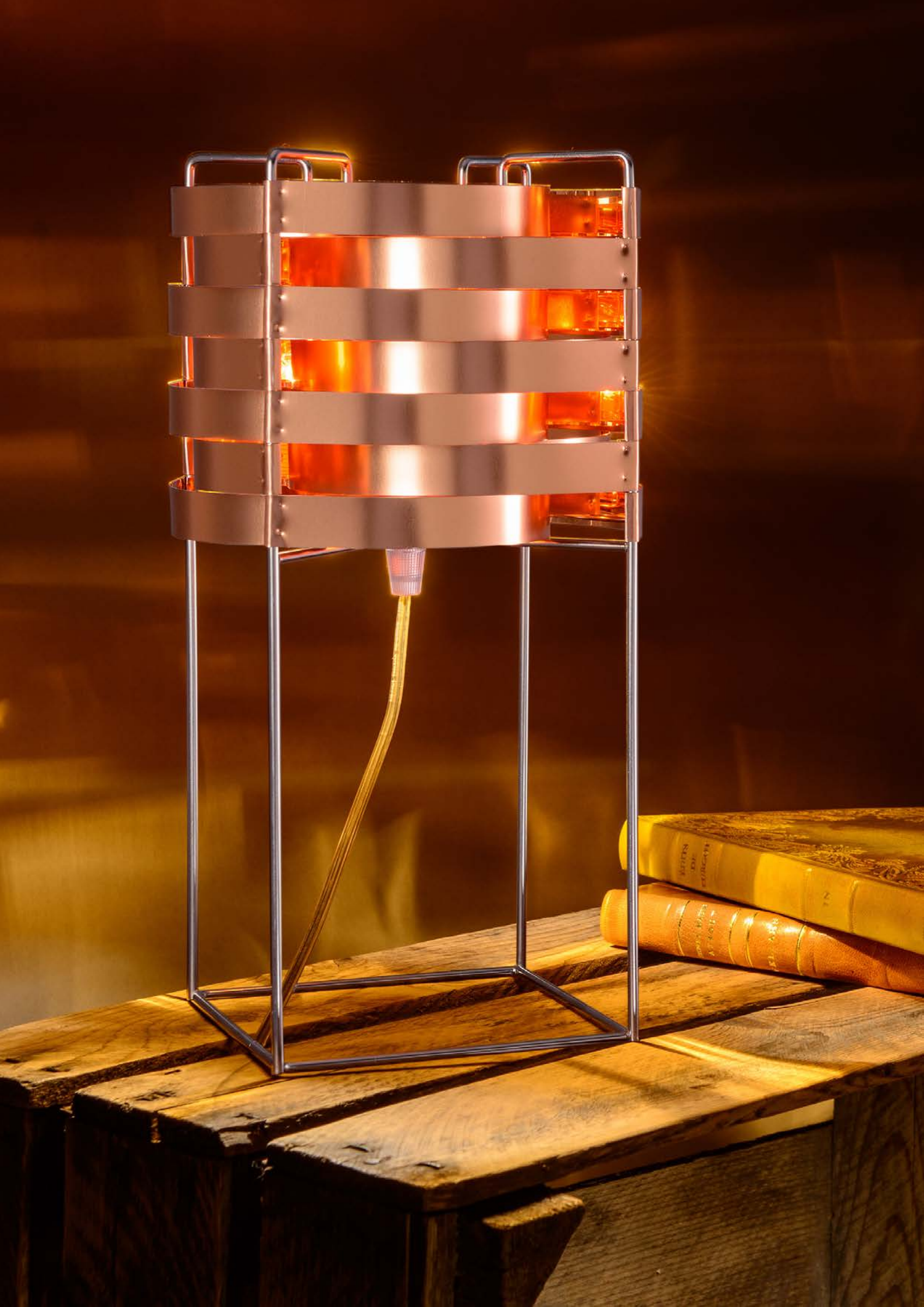

GANYMEDE





GANYMEDE





GANYMEDE II

Dimensions: 50x20 cm
Ref: GA2
1,1 kg équipée / complete
Source: E14-LED

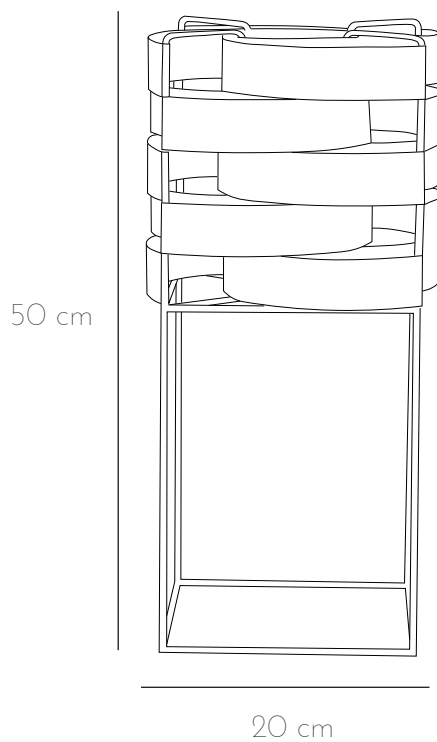



ORION SUR PIETEMENT

ORION 48

Dimensions: 48x115 cm

Ref: O48P93

5 kg-5,5kg équipée / complete

Dimensions: 48x130 cm

Ref: O48P110

5 kg- 5,5 kg équipée / complete

ORION 60

Dimensions: 60x140 cm

Ref: O60P

6kg équipée / complete

ORION 75

Dimensions: 75x170 cm

Ref: O75P

9kg équipée / complete

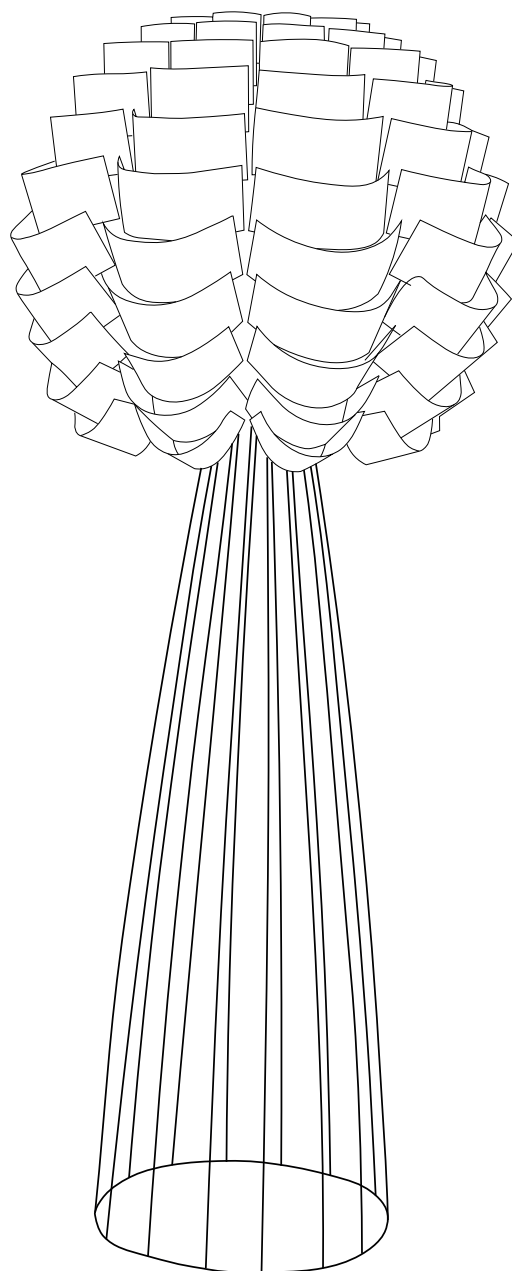

115 / 130 / 140 / 170 cm

48 / 60 / 75 cm



ORION SUSPENSION

ORION 48

Dimensions: 48x40 cm

Ref: O48

2kg-2,5 kg équipée / complete

ORION 60

Dimensions: 60x50 cm

Ref: O60

3kg équipée / complete

ORION 75

Dimensions: 75x60 cm

Ref: O75

5kg équipée / complete

Source: E27

ORION 100

Dimensions: 100x85 cm

Ref: O100

9 kg équipée / complete

Source: x2 E27

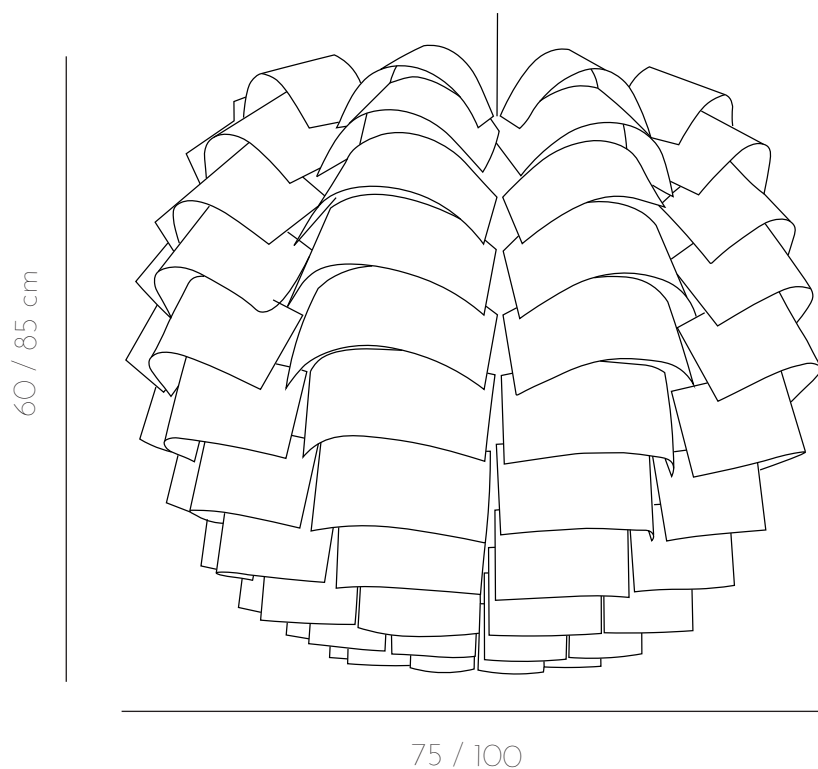
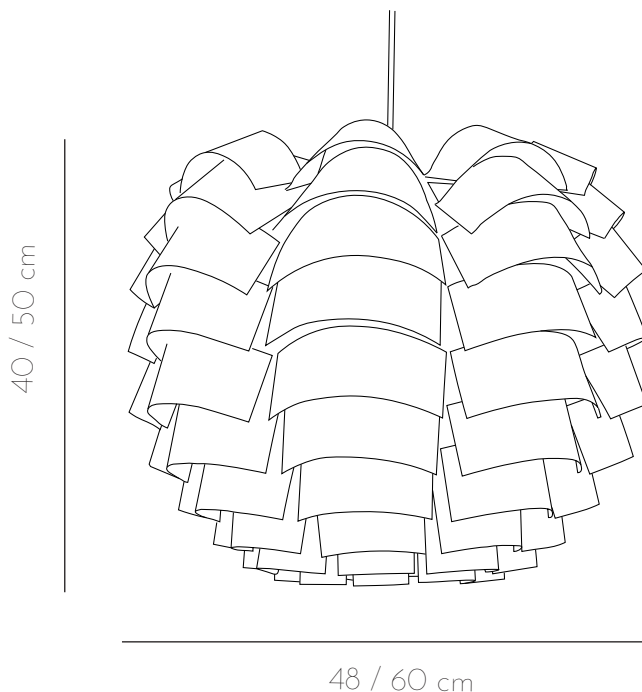



ORION 48

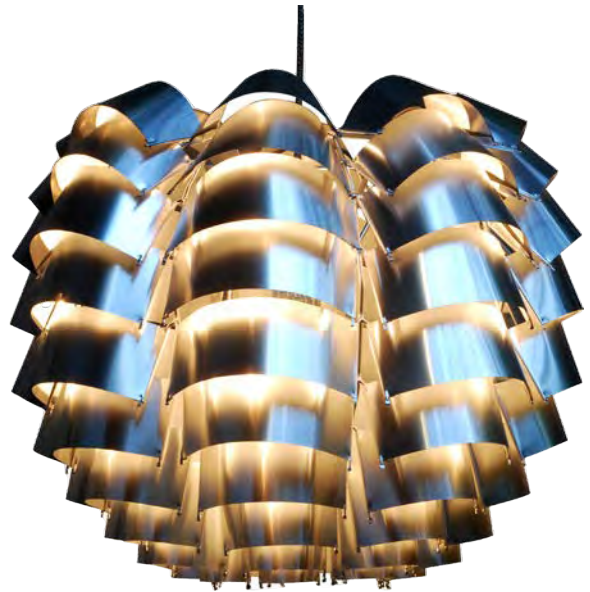



ORION 48





ORION 48





ORION 60





ORION 60





ORION 60





ORION 75





ORION 75





ORION 100





ORION 100

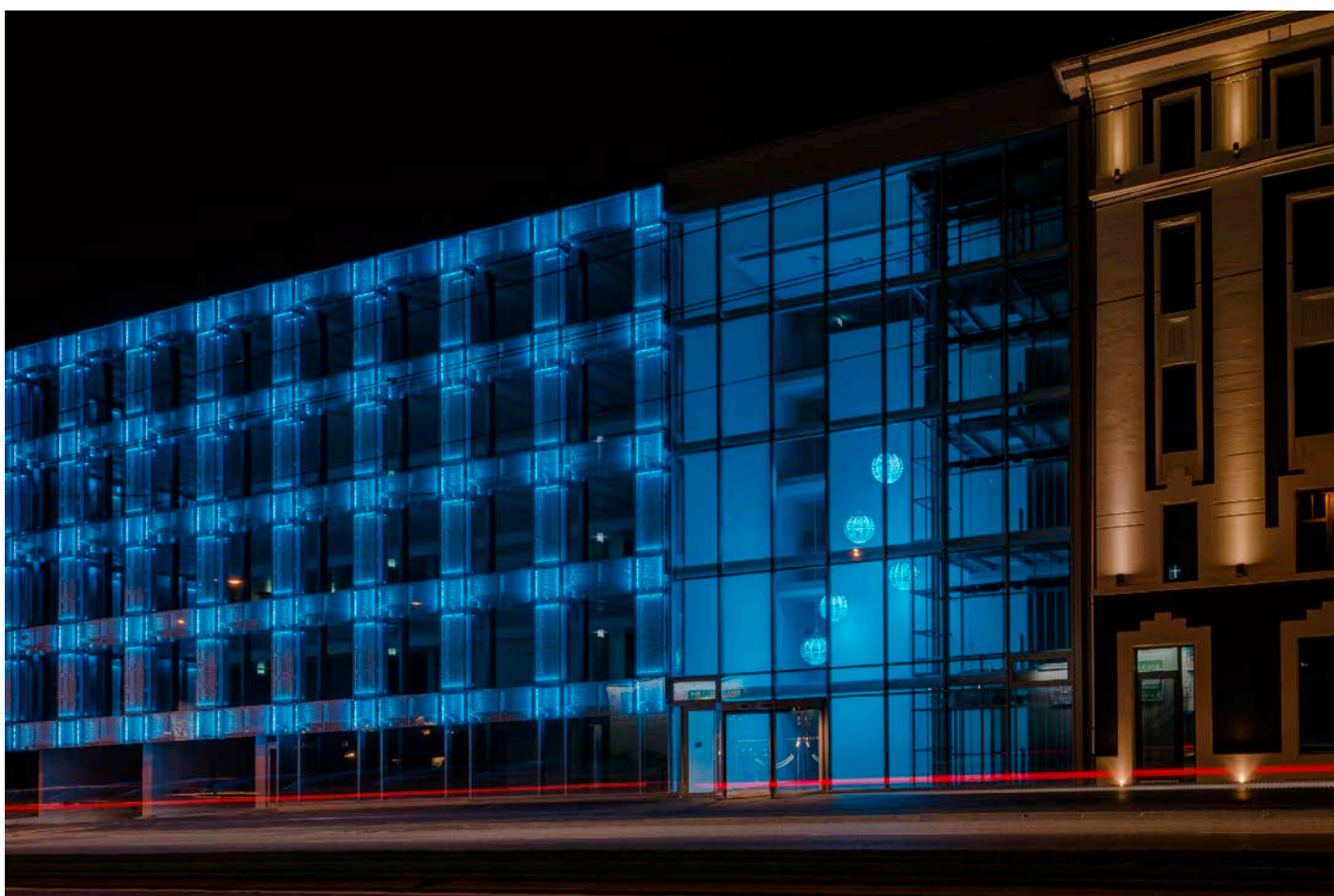

Projet Genève

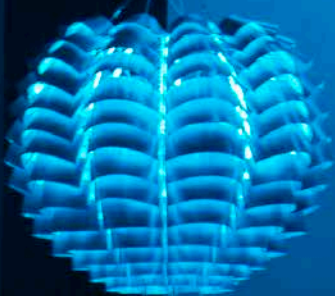
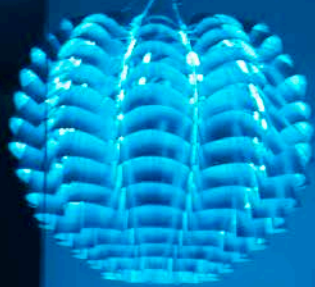
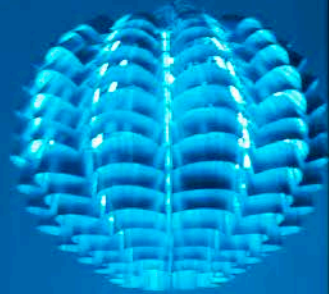
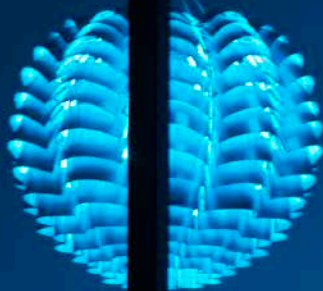
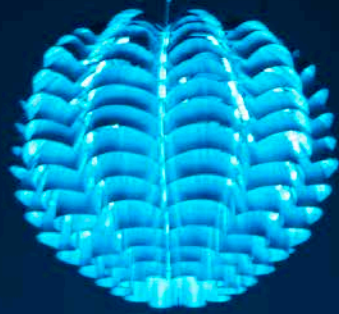

ORION 100





ORION 130





PROJET TCHOURI





Projet sur demande

